

Engine 4TNV98  
Engine power 46,3 kW - 62,9 HP  
Operating Weight 9.900 kg

**ES 95 TR**

Concrete solutions. Always



 **EUROCOMACH®**

# TECHNICALS SPECIFICATIONS

Operating weight (with rubber track)	kg	9.900
Operating weight (with steel track)	kg	10.220
Travelling speed (AUTO TWO SPEED)	km/h	1 <sup>a</sup> : 0 ÷ 2,6 / 2 <sup>a</sup> : 0 ÷ 5,2
Slew speed	rpm	10

ENGINE		
Type	YANMAR 4TNV98	
Power (2.200 rpm)	kW - HP	46,3 - 62,9
Displacement	cc	3.319
Number of cylinders	n°	4
Cooling	water	
Consumption	lt/h	8,7
Alternator	V (A)	12 (55)
Battery	V (Ah)	12 (100)

HYDRAULIC SYSTEM		
Circuit Type	Load Sensing closed center system with "Flow Sharing" control valve	
Pump type	1 LS variable pump + 1 gear pump	
Pump displacement	cc	84 + 9
Pump capacity	lt/min	185 + 20
Max. circuit calibration pressure	bar	290 - 200 - 35
Auxiliary Flow (max pressure):	lt/min (bar)	100 / 100 (200) 90 / 80 (290)
AUX 1 main high flow simple or double effect		
AUX 2 double effect		

PERFORMANCES		
Max digging depth standard arm (optional arm)	mm	4.570 (4.920)
Max dumping height with cab standard arm (optional arm)	mm	6.070 (6.370)
Bucket breaking force (standard arm) ISO 6015	daN	5.500
Arm breaking force (standard arm) ISO 6015	daN	4.350
Traction force	daN	7.960
Ground bearing pressure with rubber tracks	kg/cm <sup>2</sup>	0,46
Max slope	60% - 30°	

DIMENSIONS		
Max. width	mm	2.320
Total height	mm	2.560
Rear rotation radius	mm	1.155
Digging arm length std (optional)	mm	1.760 (2.110)
Tracks width	mm	450
Rollers number (for each side)	n°	5/1 (rubber track) 6/1 (steel track)

FILLINGS		
Fuel tank	lt	105
Hydraulic oil tank	lt	90
Hydraulic circuit capacity	lt	120
Cooling system capacity	lt	25
Engine oil	lt	10

CONTROLS		
Boom, dipper stick, bucket and turret swing	2 pilot joysticks	
Tracks movement (included counter rotation)	2 pilot levers	
Dozer blade	pilot lever	
Auxiliary circuit main high flow with latch AUX 1 (simple or double effect)	electroproportional switch on right joystick	
Auxiliary circuit AUX 2 (double effect)	electroproportional switch on right joystick	
Boom swing	electroproportional switch on left joystick	

# ES 95 TR

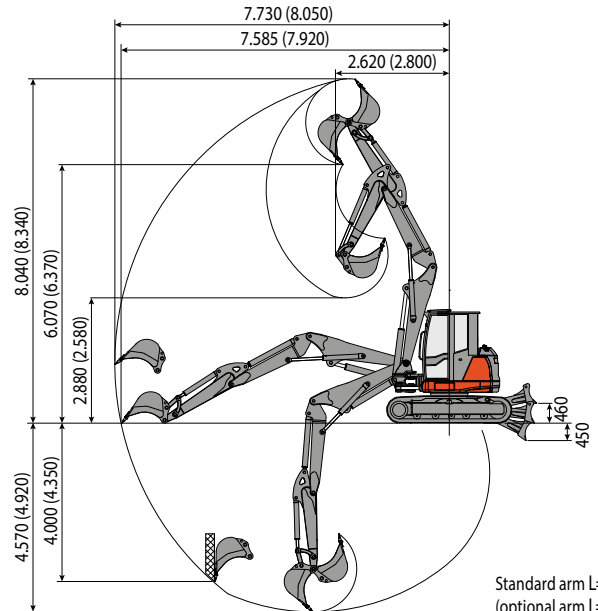

Standard arm L=1.770  
(optional arm L=2.110)

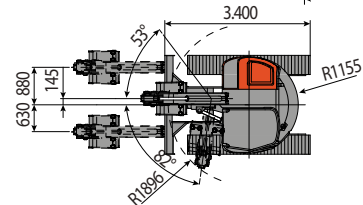
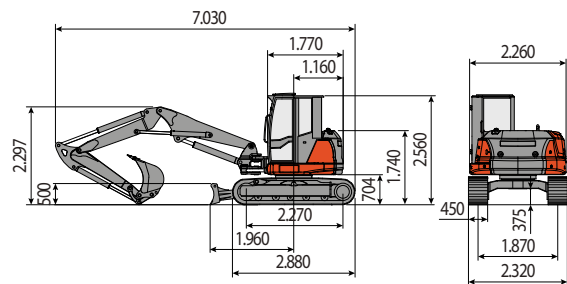

LIFTING CAPACITY					
Opening arm from the rotation's center (m)					
Lifting capacity (kg) at 1.5 m height					
	3	4	5	6	MAX
Frontal and lowered dozer blade	4045	2830	2110	1750	1580
Frontal and lifted dozer blade	2760	1930	1235	1000	920
Lateral	3150	1760	1300	990	840

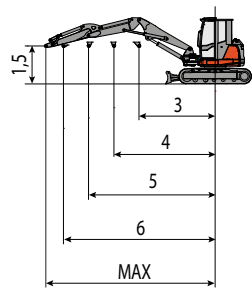

The lifting capacity is based on the ISO 10567 and it does not exceed more than the 75% of static tipping load or more than the 87% of the hydraulic lifting capacity of the machine.



**EUROCOMACH**



Sampierana S.p.A.

47021 S.Piero in Bagno (FC)

via Leonardo da Vinci, 40

Tel +39 0543.904211

Fax +39 0543.918520

www.eurocomach.com